

# Crystal Clear Technology

## Product Specification

### T500A23X00X

(REVISION 3)

Customers are requested to read through and understand this product specification. If no feedback is received from customer by 30 days, it is deemed that customer has fully need, understand and agreed on the specification set forth in this document.

Acknowledged by,

Date: \_\_\_\_\_

\_\_\_\_\_

(CUSTOMER'S SIGNATURE)

REMARK: AFTER THE ACKNOWLEDGEMENT HAS BEEN SIGNED, PLEASE RETURN TO CCT.

## Crystal Clear Technology sdn. bhd.

16 Jalan TP5, Taman Perindustrian Sime UEP,  
47600 Subang Jaya, Selangor DE  
Malaysia.

T: +603 80247099

Website: [www.cct.com.my](http://www.cct.com.my)

---



**1. Table of Contents**

| No | Title                       | Page |
|----|-----------------------------|------|
| 1  | Table of Contents           | 2    |
| 2  | Record of Revision          | 3    |
| 3  | General Specification       | 4    |
| 4  | AC/DC Characteristics (TFT) | 6    |
| 5  | AC/DC Characteristics (CTP) | 9    |
| 6  | Optical Characteristics     | 12   |
| 7  | Reliability Test Condition  | 14   |
| 8  | Inspection Criteria         | 15   |
| 9  | Precaution                  | 18   |
| 10 | Mechanical Specification    | 22   |
|    |                             |      |
|    |                             |      |
|    |                             |      |
|    |                             |      |
|    |                             |      |
|    |                             |      |
|    |                             |      |
|    |                             |      |
|    |                             |      |
|    |                             |      |
|    |                             |      |
|    |                             |      |
|    |                             |      |
|    |                             |      |
|    |                             |      |



## 2. Record of Revision

| Rev  | Date     | Item | Page | Comment                             | Prepared | Checked |
|------|----------|------|------|-------------------------------------|----------|---------|
| REV1 | 09/08/19 |      |      | Initial Release                     | Fathiyah | Whong   |
| REV2 | 28/02/20 | 4.3  | 7    | Revised LED Backlight Specification | Fathiyah | Whong   |
|      |          | 10   | 23   | Revised note (2)                    |          |         |
| REV3 | 28/03/20 | 10   | 24   | Revised Mechanical Drawing          |          |         |
|      |          |      |      | Added Mechanical Drawing            | Fathiyah | Whong   |



### 3. General Specification

T500A23X00X is 5.0" color TFT-LCD (Thin Film Transistor Liquid Crystal Display) module composed of LCD panel, driver ICs control circuit, LED backlight and Touch Panel. This display area contains 800(RGB) x 480 pixels and can display up to 16.7M colors. This product compliant with RoHS environmental requirement and Halogen Free.

|                     | Item                  | Specifications                 | Unit                | Note |
|---------------------|-----------------------|--------------------------------|---------------------|------|
|                     | Size (Diagonal)       | 5.0                            | inch                |      |
|                     | Outline dimensions    | 120.7 (W) x 75.8 (H) x 2.9 (T) | mm                  | (1)  |
| TFT                 | Display type          | IPS, Normally Black            | -                   | (2)  |
|                     | Viewing direction     | All                            | O'clock             |      |
|                     | TFT Active area       | 108.0 (W) x 64.8 (H)           | mm                  |      |
|                     | TFT Resolution        | 800(RGB) x 480                 | -                   |      |
|                     | Pixel size            | 0.135(W) x 0.135(H)            | mm                  |      |
|                     | Pixel arrangement     | RGB vertical stripe            | -                   |      |
|                     | TFT Driving IC        | ST7262 or compatible           | -                   |      |
|                     | Interface mode        | RGB                            | -                   |      |
|                     | Luminance             | 600                            | cd/m <sup>2</sup>   | (3)  |
|                     | CTP                   | CTP Active area                | 108.0(W) x 64.8 (H) | mm   |
| CTP Resolution      |                       | 800 x 480                      | -                   |      |
| CTP Origin          |                       | Top-left (FPC down)            | -                   |      |
| CTP Controller      |                       | GT911                          | -                   |      |
| CTP Interface mode  |                       | I2C                            | -                   |      |
| Touch mode          |                       | Five concurrent touches        | -                   |      |
| Cover lens material |                       | Glass                          | -                   |      |
|                     | Operating temperature | -20 to +70                     | °C                  | (4)  |
|                     | Storage temperature   | -30 to +80                     | °C                  | (4)  |

Note:

- (1) FPC or Wire or Foam Tape or CTP or RTP are not included.
- (2) Color tone is slightly changed by temperature and driving voltage.
- (3) Brightness on LCD surface. Module with CTP or RTP, brightness will be about 20% (max) lower on the touch panel surface.
- (4) This product specification shows range of value either in the minimum, typical or maximum category. Operating under extreme condition, bordering on the minimum or maximum range, does not mean that the product can survive perpetually under these extremities. In fact, it only means that the product can operate under such condition with no information of lifetime, other than those already indicated in the specification. User is advised to test it on their own if the specification's reliability data did not indicate it.

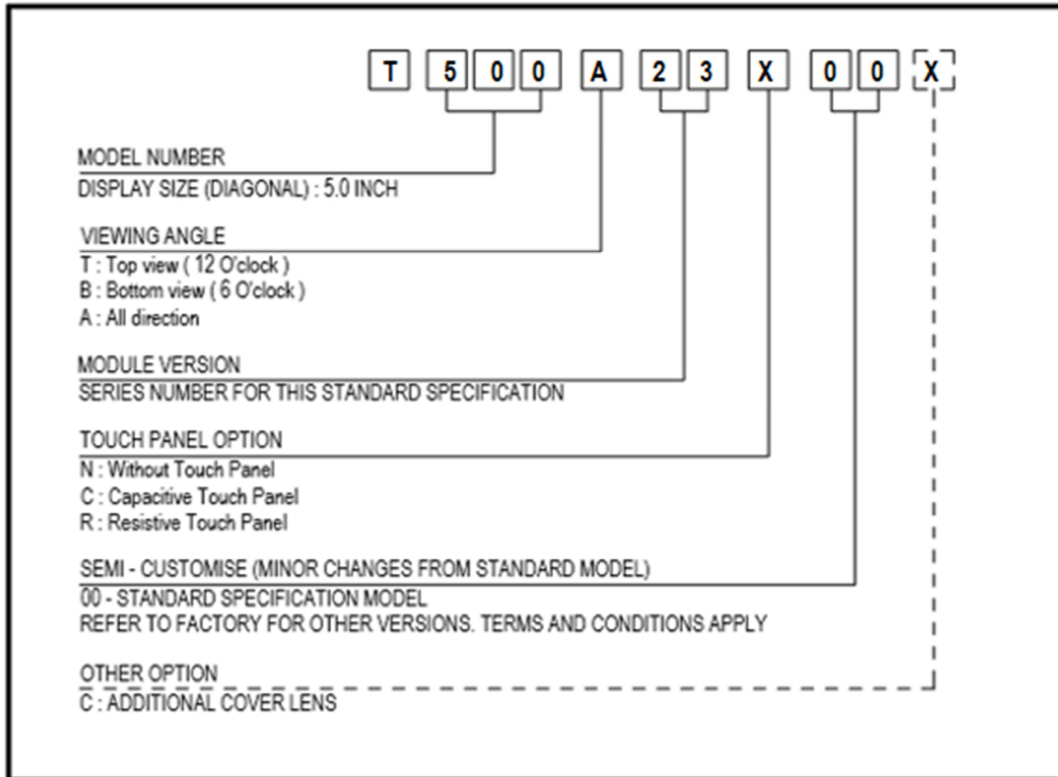



## 4. AC/DC Characteristics (TFT)

### 4.1 Absolute Maximum Ratings ( $V_{SS} = 0V$ , $T_a = 25^\circ C$ )

| Item                      | Symbol   | Min  | Typ | Max  | Unit       | Note |
|---------------------------|----------|------|-----|------|------------|------|
| Power Supply Voltage      | $V_{DD}$ | -0.3 | -   | +4.0 | V          |      |
| Backlight Forward Current | $I_f$    | -    | -   | 180  | mA         |      |
| Storage Humidity          | $H_{ST}$ | 10   | -   | 90   | %RH        | (1)  |
| Storage Temperature       | $T_{ST}$ | -30  | -   | +80  | $^\circ C$ |      |
| Operating Humidity        | $H_{OP}$ | 10   | -   | 90   | %RH        | (1)  |
| Operating Temperature     | $T_{OP}$ | -20  | -   | +70  | $^\circ C$ |      |

Note:

- (1) At  $25 \pm 5^\circ C$ . Absolute humidity shall be less than 90%RH at  $+50^\circ C$ .
- (2) Stresses above those listed under "Absolute Maximum Ratings" may cause permanent damage to the device. These are stress ratings only. Functional operation of this device at these or any other conditions above those indicated in the operational sections of this specification is not implied and exposure to absolute maximum rating conditions for extended periods may affect device reliability.

### 4.2 Electrical Characteristics ( $V_{SS} = 0V$ , $V_{DD} = 3.3V$ , $T_a = 25^\circ C$ )

| Item                      | Symbol   | Min            | Typ | Max          | Unit | Note |
|---------------------------|----------|----------------|-----|--------------|------|------|
| Power Supply Voltage      | $V_{DD}$ | 3.3            | -   | 3.6          | V    |      |
| Operation Current         | $I_{DD}$ | -              | TBA | -            | mA   |      |
| Input Logic High Voltage  | $V_{IH}$ | $0.7 V_{DD}$   | -   | $V_{DD}$     | V    |      |
| Input Logic Low Voltage   | $V_{IL}$ | 0              | -   | $0.3 V_{DD}$ | V    |      |
| Output Logic High Voltage | $V_{OH}$ | $V_{DD} - 0.4$ | -   | $V_{DD}$     | V    |      |
| Output Logic Low Voltage  | $V_{OL}$ | 0              | -   | 0.4          | V    |      |

Note:

- (1) The recommended operating conditions refer to a range in which operation of this product is guaranteed. Accordingly, please make sure that the module is used within this range. And these current values are measured under the condition that all devices are stopped, each component is stable and logic signal is input.



**4.3 LED Backlight Specification (Ta = 25°C)**

| Item                 | Symbol                                    | Condition     | Min   | Typ | Max | Unit              |
|----------------------|---|---------------|-------|-----|-----|-------------------|
| LED Supply Voltage   | Vf  | If = 50mA     | -     | 16  | -   | V                 |
| LED Supply Current   | If  |               | -     | 50  | -   | mA                |
| Luminous Intensity   | Lv  | White         | -     | 600 | -   | cd/m <sup>2</sup> |
| Half Life Expectancy | LL  | If = 20mA/LED | 30000 |     |     | hrs               |
| LED Configuration    | 18 White LEDs, 3 in series, 6 in parallel |               |       |     |     |                   |

Note:

- (1) The LED Supply Voltage is defined by the number of LED at Ta = 25°C and If = 50mA.
- (2) The “Half Life Expectancy” is defined as the module brightness decrease to 50% of original brightness at Ta = 25°C and If = 20mA/LED. The LED lifetime can decrease if the operating If is higher than 20mA/LED.
- (3) Brightness measurement done at LCD surface.



#### 4.4 Pin Assignment Table

##### 4.4.1 FPC Pin Out

| Pin No. | Symbol  | I/O | Description                              | Note |
|---------|---------|-----|--|------|
| 1       | GLED    | P   | Backlight Supply Cathode                 |      |
| 2       | VLED    | P   | Backlight Supply Anode                   |      |
| 3       | GND     | P   | Ground                                   |      |
| 4       | VDD     | P   | Power Supply                             |      |
| 5 - 12  | R0 – R7 | I   | Red Data                                 |      |
| 13 - 20 | G0 – G7 | I   | Green Data                               |      |
| 21 - 28 | B0 – B7 | I   | Blue Data                                |      |
| 29      | GND     | P   | Ground                                   |      |
| 30      | DCLK    | I   | Data Clock                               |      |
| 31      | DISP    | I   | Display ON/OFF Control                   | (1)  |
| 32      | HS      | I   | Horizontal Synchronize Input in RGB mode |      |
| 33      | VS      | I   | Vertical Synchronize Input in RGB mode   |      |
| 34      | DE      | I   | Data Enable                              |      |
| 35      | NC      | -   | No Connection                            |      |
| 36      | GND     | P   | Ground                                   |      |
| 37      | NC (XR) | -   | X Right (RTP)                            |      |
| 38      | NC (YD) | -   | Y Bottom (RTP)                           |      |
| 39      | NC (XL) | -   | X Left (RTP)                             |      |
| 40      | NC (YU) | -   | Y Top (RTP)                              |      |

Note:

(1) L: Standby mode, H: Display ON





## 5. AC/DC Characteristics (CTP)

### 5.1 Absolute Maximum Ratings (VSS = 0V, Ta = 25°C)

| Item                              | Symbol | Min  | Typ | Max  | Unit | Note |
|-----------------------------------|--------|------|-----|------|------|------|
| Voltage Supply                    | VDD    | 2.66 | -   | 3.47 | V    |      |
| Voltage acceptable to digital I/O | VDDIO  | -0.3 | -   | 3.47 | V    |      |
| Storage Humidity                  | HST    | 10   | -   | 90   | %RH  | (1)  |
| Storage Temperature               | TST    | -30  | -   | +80  | °C   |      |
| Operating Humidity                | HOP    | 10   | -   | 90   | %RH  | (1)  |
| Operating Temperature             | TOP    | -20  | -   | +70  | °C   |      |

Note:

- (1) At 25±5°C. Absolute humidity shall be less than 90%RH at +50°C.
- (2) Stresses above those listed under “Absolute Maximum Ratings” may cause permanent damage to the device. These are stress ratings only. Functional operation of this device at these or any other conditions above those indicated in the operational sections of this specification is not implied and exposure to absolute maximum rating conditions for extended periods may affect device reliability.

### 5.2 Electrical Characteristics (VSS = 0V, VDD = 2.8V, Ta = 25°C)

| Item                        | Symbol | Min       | Typ | Max       | Unit | Note |
|-----------------------------|--------|-----------|-----|-----------|------|------|
| Voltage Supply              | VDD    | 2.8       | -   | 3.3       | V    |      |
| Operation Current           | IDD    | -         | 8   | 14.5      | mA   |      |
| Digital Input Low Voltage   | VIL    | -0.3      | -   | 0.25* VDD | V    |      |
| Digital Input High Voltage  | VIH    | 0.75* VDD | -   | VDD+0.3   | V    |      |
| Digital Output Low Voltage  | VOL    | -         | -   | 0.15* VDD | V    |      |
| Digital Output High Voltage | VOH    | 0.85* VDD | -   | -         | V    |      |

Note:

- (1) The recommended operating conditions refer to a range in which operation of this product is guaranteed. Accordingly, please make sure that the module is used within this range. And these current values are measured under the condition that all devices are stopped, each component is stable and logic signal is input.

### 5.3 I2C Interface

Touch panel is used as I2C slave device, GT911 supports two I2C slave address, 0xBA/0xBB and 0x28/0x29. The host can select the address by changing the status of Reset and INT pins during the power-on initialization phase.



**5.4 I2C Timing Characteristics** ( $V_{SS} = 0V$ ,  $V_{DD} = 3.3V$ ,  $T_a = 25^\circ C$ )

**5.4.1 I2C Timing Diagram**

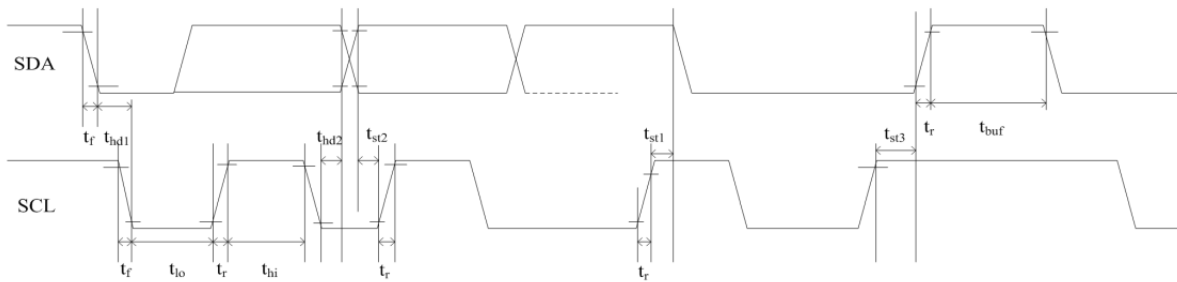

| Parameter                          | Symbol           | Min | Typ | Max | Unit |
|------------------------------------|------------------|-----|-----|-----|------|
| SCL Low Period                     | t <sub>lo</sub>  | 1.3 | -   | -   | us   |
| SCL High Period                    | t <sub>hi</sub>  | 0.6 | -   | -   | us   |
| SCL Setup time for START condition | t <sub>st1</sub> | 0.6 | -   | -   | us   |
| SCL Setup time for STOP condition  | t <sub>st3</sub> | 0.6 | -   | -   | ns   |
| SCL Hold Time for START condition  | t <sub>hd1</sub> | 0.6 | -   | -   | ns   |
| SDA Setup Time                     | t <sub>st2</sub> | 0.1 | -   | -   | us   |
| SDA Hold Time                      | t <sub>hd2</sub> | 0   | -   | -   | ns   |

**5.4.2 Power-on Timing**

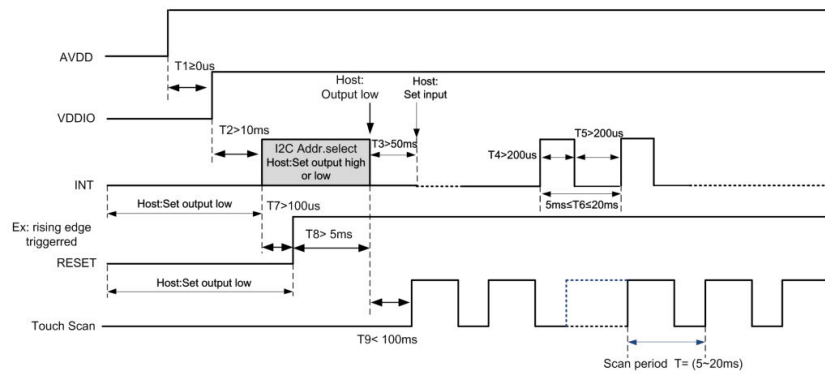

**5.4.3 Timing for Host Resetting GT911**

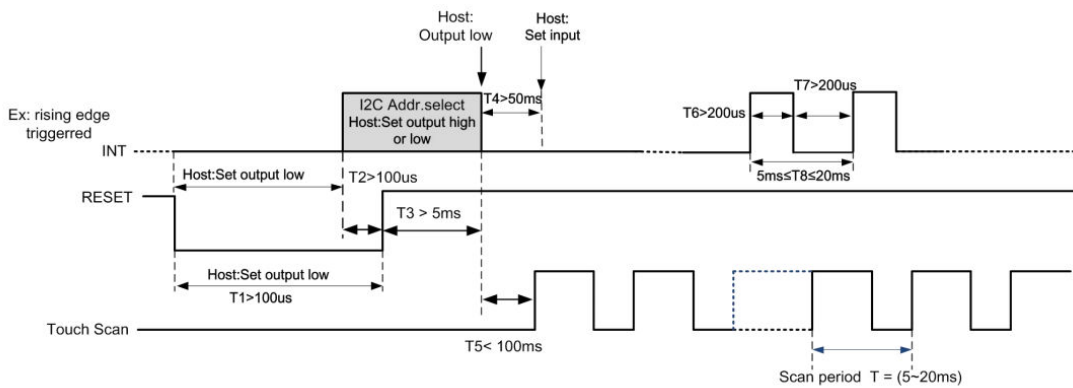



### 5.4.4 Timing for Setting Slave Address to 0x28/0x29

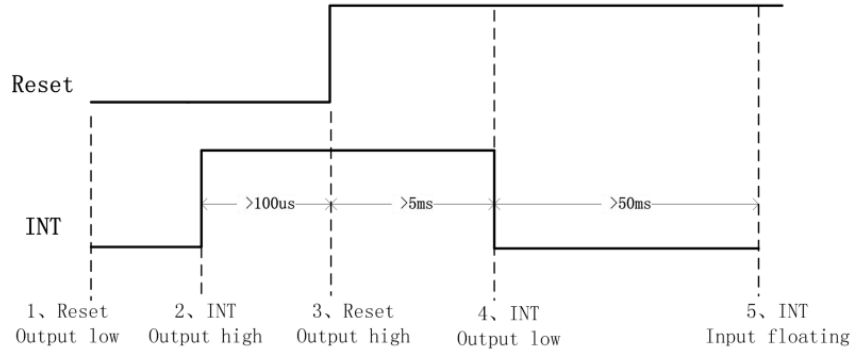

### 5.4.5 Timing for Setting Slave Address to 0xBA/0xBB

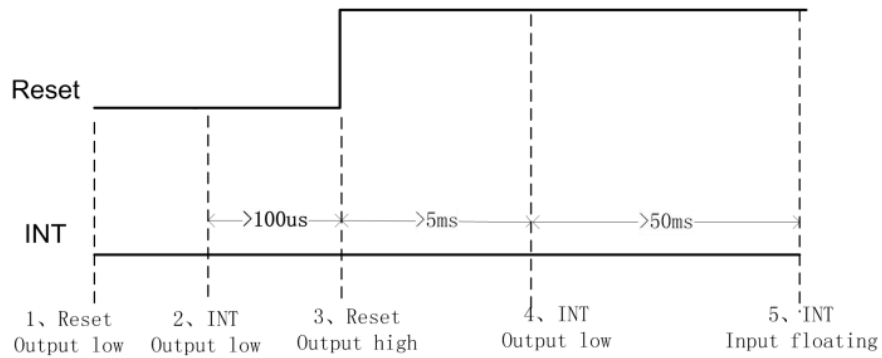

## 5.5 Pin Assignment Table

| Pin No. | Symbol | I/O | Description      | Note |
|---------|--------|-----|------------------|------|
| 1       | RST    | I   | Reset            | (1)  |
| 2       | VDD    | P   | Power Supply     |      |
| 3       | GND    | P   | Ground           |      |
| 4       | INT    | O   | Interrupt        | (2)  |
| 5       | SDA    | I/O | I2C Serial Data  |      |
| 6       | SCL    | I   | I2C Serial Clock |      |

Note:

(1) RST = Active Low

(2) INT = Active Low

## 6. Optical Characteristics

| Item           | Symbol  | Condition                          | Min | Typ  | Max | Unit              | Note |
|----------------|---------|------------------------------------|-----|------|-----|-------------------|------|
| Brightness     | Bp      | $\theta=0^\circ$<br>$\Phi=0^\circ$ | -   | 600  | -   | cd/m <sup>2</sup> | (2)  |
| Viewing Angle  | 3:00    | Cr $\geq$ 10                       | 70  | 80   | -   | degree            | (3)  |
|                | 6:00    |                                    | 70  | 80   | -   |                   |      |
|                | 9:00    |                                    | 70  | 80   | -   |                   |      |
|                | 12:00   |                                    | 70  | 80   | -   |                   |      |
| Contrast Ratio | Cr      | $\theta=0^\circ$<br>$\Phi=0^\circ$ | 800 | 1000 | -   | -                 | (4)  |
| Response Time  | Tr / Tf | Ta=25°C.                           | -   | 30   | 40  | ms                | (5)  |

Note:

- (1) The parameter is slightly changed by temperature, driving voltage and materiel.
- (2) The data are measured after LEDs are turned on for 5 minutes. LCM displays full white. The brightness is the average value of 9 measured spots. Measurement equipment BM-7A.

Measuring condition:

- Measuring surroundings: Dark room.
- Measuring temperature: Ta=25°C.
- Adjust operating voltage to get optimum contrast at the center of the display.

Measured value at the center point of LCD panel after more than 5 minutes while backlight turning on.

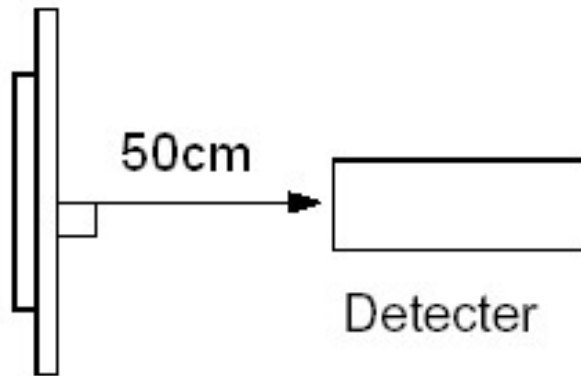

- (3) The definition of viewing angle:  
Refer to the graph below marked by  $\theta$  and  $\Phi$

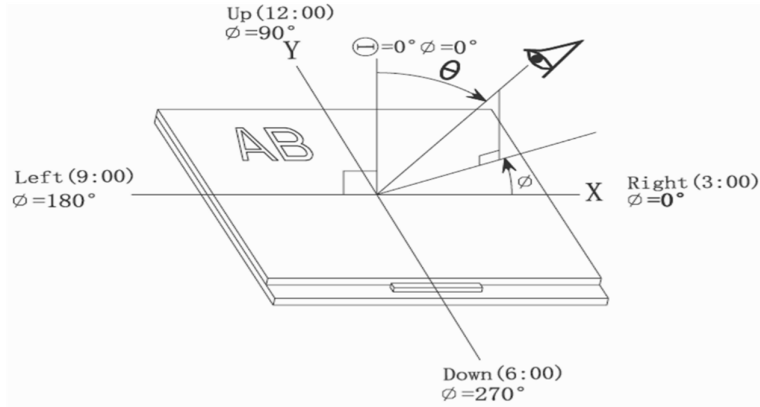

- (4) Definition of contrast ratio.

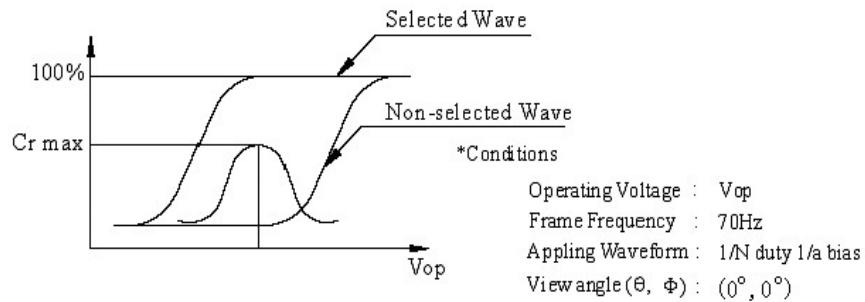

$$\text{Contrast ratio (Cr)} = \frac{\text{Brightness of selected dots}}{\text{Brightness of non-selected dots}}$$

- (5) Definition of Response time.  
The output signals of photo detector are measured when the input signals are changed from “black” to “white” (falling time) and from “white” to “black” (rising time), respectively. The response time is defined as the time interval between the 10% and 90% of amplitudes. Refer to figure as below.

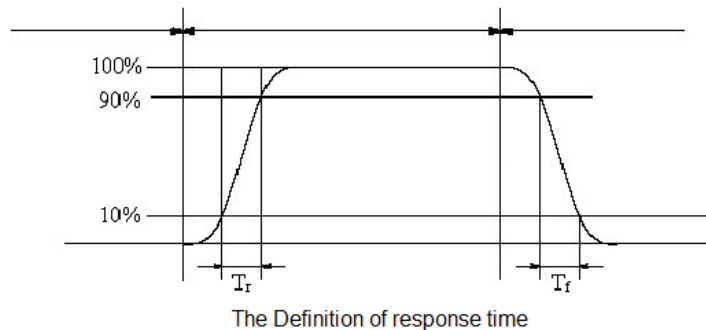



### 7. Reliability Test Condition

| Item      |                                    | Test Condition   | Note      |
|-----------|------------------------------------|--|-----------|
| Operating | High Temperature                   | +70°C, 240hrs  | (3)       |
|           | Low Temperature                    | -20°C, 240hrs  | (3)       |
|           | Cycle                              | RT (0m) → -20°C (30m) → RT (5m) → +70°C (30m) → RT (5m)<br>50 cycles | (1)(2)(3) |
| Storage   | High Temperature                   | +80°C, 240hrs  | (3)       |
|           | Low Temperature                    | -30°C, 240hrs  | (3)       |
|           | High Temperature and High Humidity | +50°C, 90%RH, 240hrs   | (3)(4)    |

Note:

- (1) RT means Room Temperature.
- (2) m means minute.
- (3) Before cosmetic and functional test, the product must have enough recovery time, at least 2 hours at room temperature.
- (4) No condensation

### 8. Inspection Criteria

- Inspection distance: 25~30cm.
- From lamp source to product: 250 ± 100cm.
- Angle of inspection: Ambient brightness 1k-1.5k lux inspection from front view, perpendicular to the surface of product.

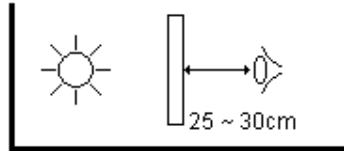



| No                    | Defect  | Definition of defect   | Inspection Criteria  |            |                       |   |                     |            |   |   |    |          |   |   |       |   |  |  |
|-----------------------|---|--|--|------------|-----------------------|---|---------------------|------------|---|---|----|----------|---|---|-------|---|--|--|
| 1                     | a) Definition of dot  | <p>The size of defective dot over 1/2 of whole is regards as one defective dot.</p> <p>Smaller than 1/2      Larger than 1/2</p> <p>'No dot defect' (ignore)      '1 dot defect' (counted)</p>                       | <p>A - Viewing area<br/>B - Viewing area<br/>C - Outside Viewing area</p>  |            |                       |   |                     |            |   |   |    |          |   |   |       |   |  |  |
|                       | b) Bright Dot   | Dot appear bright and unchanged in size when LCD panel is displaying black pattern.  | <table border="1"> <thead> <tr> <th>Defect</th> <th>A</th> <th>B</th> <th>C</th> </tr> </thead> <tbody> <tr> <td>Bright Dot</td> <td>1</td> <td>1</td> <td rowspan="2">NC</td> </tr> <tr> <td>Dark Dot</td> <td>2</td> <td>2</td> </tr> <tr> <td>Total</td> <td colspan="2">4</td> <td></td> </tr> </tbody> </table> <p>NC – Not Count</p> | Defect     | A                     | B | C                   | Bright Dot | 1 | 1 | NC | Dark Dot | 2 | 2 | Total | 4 |  |  |
|                       | Defect  | A  |  | B          | C                     |   |                     |            |   |   |    |          |   |   |       |   |  |  |
|                       | Bright Dot  | 1  | 1  | NC         |                       |   |                     |            |   |   |    |          |   |   |       |   |  |  |
| Dark Dot              | 2   | 2  |  |            |                       |   |                     |            |   |   |    |          |   |   |       |   |  |  |
| Total                 | 4   |  |  |            |                       |   |                     |            |   |   |    |          |   |   |       |   |  |  |
| c) Dark Dot           | Dot appear dark and unchanged in size when LCD panel is displaying pure color (RED, GREEN or BLUE) pattern. |  |  |            |                       |   |                     |            |   |   |    |          |   |   |       |   |  |  |
| d) 2 dot adjacent     | <p>1 pair = 2 dots</p> <p>Type 1      Type 2      or      Type 3</p>  | <table border="1"> <thead> <tr> <th>Defect</th> <th>Acc. Count</th> </tr> </thead> <tbody> <tr> <td>2 Bright dot Adjacent</td> <td>0</td> </tr> <tr> <td>2 Dark dot Adjacent</td> <td>1</td> </tr> </tbody> </table> | Defect   | Acc. Count | 2 Bright dot Adjacent | 0 | 2 Dark dot Adjacent | 1          |   |   |    |          |   |   |       |   |  |  |
| Defect                | Acc. Count  |  |  |            |                       |   |                     |            |   |   |    |          |   |   |       |   |  |  |
| 2 Bright dot Adjacent | 0   |  |  |            |                       |   |                     |            |   |   |    |          |   |   |       |   |  |  |
| 2 Dark dot Adjacent   | 1   |  |  |            |                       |   |                     |            |   |   |    |          |   |   |       |   |  |  |
| 2                     | <p>a) Black Spot<br/>b) White Spot<br/>c) Bright Spot<br/>d) Pin Hole<br/>e) Foreign Particle</p>           | <p>- Black / Dark / Bright Spot is points on display which appear dark/bright and usually result from contamination.<br/>- These defect do not vary in size intensity (contrast) when contrast is varied.</p>        | <p>A - Viewing area<br/>B - Outside Viewing area</p>   |            |                       |   |                     |            |   |   |    |          |   |   |       |   |  |  |



|  |                 |   | <table border="1"> <thead> <tr> <th>Defect Category</th> <th>A</th> <th>B</th> </tr> </thead> <tbody> <tr> <td>D &lt; 0.15</td> <td>NC</td> <td rowspan="4">NC</td> </tr> <tr> <td>0.15 ≤ D &lt; 0.25</td> <td>2</td> </tr> <tr> <td>0.25 ≤ D ≤ 0.30</td> <td>1</td> </tr> <tr> <td>D &gt; 0.30</td> <td>0</td> </tr> </tbody> </table> | Defect Category | A | B        | D < 0.15 | NC | NC              | 0.15 ≤ D < 0.25 | 2               | 0.25 ≤ D ≤ 0.30 | 1        | D > 0.30 | 0 |
|--|-----------------|---|---|-----------------|---|----------|----------|----|-----------------|-----------------|-----------------|-----------------|----------|----------|---|
| Defect Category  | A               | B   |   |                 |   |          |          |    |                 |                 |                 |                 |          |          |   |
| D < 0.15   | NC              | NC  |   |                 |   |          |          |    |                 |                 |                 |                 |          |          |   |
| 0.15 ≤ D < 0.25  | 2               |   |   |                 |   |          |          |    |                 |                 |                 |                 |          |          |   |
| 0.25 ≤ D ≤ 0.30  | 1               |   |   |                 |   |          |          |    |                 |                 |                 |                 |          |          |   |
| D > 0.30   | 0               |   |   |                 |   |          |          |    |                 |                 |                 |                 |          |          |   |
| a) Black Line<br>b) White Line<br>c) Particle between POL and Glass<br>d) Scratch on Glass |                 | <table border="1"> <thead> <tr> <th>Defect Category</th> <th>A</th> <th>B</th> </tr> </thead> <tbody> <tr> <td>W &lt; 0.03</td> <td>NC</td> <td rowspan="4">NC</td> </tr> <tr> <td>0.03 ≤ W ≤ 0.1</td> <td>2</td> </tr> <tr> <td>L ≤ 3.0</td> <td rowspan="2">0</td> </tr> <tr> <td>L &gt; 3.0</td> </tr> </tbody> </table>             | Defect Category   | A               | B | W < 0.03 | NC       | NC | 0.03 ≤ W ≤ 0.1  | 2               | L ≤ 3.0         | 0               | L > 3.0  |          |   |
| Defect Category  | A               | B   |   |                 |   |          |          |    |                 |                 |                 |                 |          |          |   |
| W < 0.03   | NC              | NC  |   |                 |   |          |          |    |                 |                 |                 |                 |          |          |   |
| 0.03 ≤ W ≤ 0.1   | 2               |   |   |                 |   |          |          |    |                 |                 |                 |                 |          |          |   |
| L ≤ 3.0  | 0               |   |   |                 |   |          |          |    |                 |                 |                 |                 |          |          |   |
| L > 3.0  |                 |   |   |                 |   |          |          |    |                 |                 |                 |                 |          |          |   |
| a) Air Bubble<br>b) POL Bubble<br>c) POL Dented  |                 | <table border="1"> <thead> <tr> <th>Defect Category</th> <th>A</th> <th>B</th> </tr> </thead> <tbody> <tr> <td>D &lt; 0.20</td> <td>NC</td> <td rowspan="4">NC</td> </tr> <tr> <td>0.20 ≤ D &lt; 0.30</td> <td>3</td> </tr> <tr> <td>0.30 ≤ D ≤ 0.50</td> <td>2</td> </tr> <tr> <td>D &gt; 0.50</td> <td>0</td> </tr> </tbody> </table> | Defect Category   | A               | B | D < 0.20 | NC       | NC | 0.20 ≤ D < 0.30 | 3               | 0.30 ≤ D ≤ 0.50 | 2               | D > 0.50 | 0        |   |
| Defect Category  | A               | B   |   |                 |   |          |          |    |                 |                 |                 |                 |          |          |   |
| D < 0.20   | NC              | NC  |   |                 |   |          |          |    |                 |                 |                 |                 |          |          |   |
| 0.20 ≤ D < 0.30  | 3               |   |   |                 |   |          |          |    |                 |                 |                 |                 |          |          |   |
| 0.30 ≤ D ≤ 0.50  | 2               |   |   |                 |   |          |          |    |                 |                 |                 |                 |          |          |   |
| D > 0.50   | 0               |   |   |                 |   |          |          |    |                 |                 |                 |                 |          |          |   |
| 3  | Mura (50% Grey) |   | Judged by Limit sample  |                 |   |          |          |    |                 |                 |                 |                 |          |          |   |
| 4  | Corner Chip     |   | Accept if (only allowed 1):-<br>a) X ≤ 1.0mm<br>b) Y ≤ 1.0mm<br>c) Z ≤ 1/2T<br>   |                 |   |          |          |    |                 |                 |                 |                 |          |          |   |
|  | Edge Chip       | - Touch sensor corner and edge chip that do not cause any damage to tracer and not visible to end-user after housing assembly.<br>- Lens edge and corner chip that is not visible to end-user after housing assembly.   | Accept if (only allowed 1):-<br>a) X ≤ 1.0mm<br>b) Y ≤ 1.0mm<br>c) Z ≤ 1/2T<br><br>Reject – if the sensor surface edge/corner chip damage circuit and visible from front view   |                 |   |          |          |    |                 |                 |                 |                 |          |          |   |
|  | Glass Crack     |   | Reject – if any crack<br>   |                 |   |          |          |    |                 |                 |                 |                 |          |          |   |

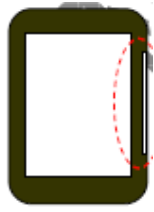
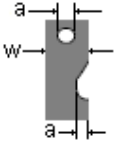

|   |                            |   |  |
|---|----------------------------|---|--|
| 5 | Printing Ink Light Leakage |   | <p>Accept if:-<br/>Light leakage at marginal area width <math>\leq 0.15\text{mm}</math></p>   |
| 6 | Surface Smudginess         | <p>- For those that can be cleaned, <math>\leq 20\%</math> of inspected quantity in one lot under &gt; class 10K area; <math>\leq 10\%</math> of inspected quantity in one lot <math>\leq</math> class 10K area.<br/>- For those that cannot be cleaned it is classified as foreign round shape defect.</p> |  |
| 7 | FPC Defects on Contact Pad |   | <p>Accept if dent, pinhole:-<br/>a) <math>a \leq w/3</math></p>  <p>Reject – if open circuit / cracking / oxidation / contamination</p> |
|   | FPC Broken                 |   | <p>Reject if FPC broken / extruded</p>   |
|   | FPC Warped                 |   | <p>Accept if FPC warped</p>    |



## 9. Precaution

### 1. Handling Precautions

- a. The display panel is made of glass and polarizer. As glass is fragile. It tends to chip during handling especially on the edges. Please avoid dropping or jarring. Do not subject it to a mechanical shock of impact or by dropping it.
- b. If the display panel is damaged and the liquid crystal substance leaks out, be sure not to get any in your mouth. If the substance is in contact with your skin or clothes, wash it off using soap and water.
- c. Do not apply excessive force to the display surface or the adjoining areas since this may cause the color tone to vary. Do not touch the display with bare hands. This will stain the display area and degrade the insulation between terminals. Scratch and dents may occur on polarizer too.
- d. The polarizer covering the display surface of the LCD module is soft and easily scratched. Handle this polarizer carefully. Do not touch, push or rub the exposed polarizers with anything harder than a HB pencil lead (glass, tweezers, etc.). Do not put or attach anything on the display area to avoid leaving marks on it. Condensation on the surface and contact with terminals due to cold will damage, stain or dirty the polarizer. After products are tested at low temperature they must be warmed up in a container before coming in to contact with room temperature air.
- e. If the display surface becomes contaminated, breathe on the surface and gently wipe it with a soft dry cloth. If it is heavily contaminated, moisten cloth with one of the following solvents.
  - Isopropyl alcohol.
  - Ethyl alcohol.
  - Do not scrub hard to avoid damaging the display surface.
- f. Solvents other than those above-mentioned may damage the polarizer. Especially, do not use the following.
  - Water.
  - Ketone.
  - Aromatic solvents.
  - Wipe off saliva or water drops immediately, contact with water over a long period of time may cause deformation or colour fading. Avoid contact with oil and fats.
- g. Exercise care to minimize corrosion of the electrode. Corrosion of the electrodes is accelerated by water droplets, moisture condensation or a current flow in a high-humidity environment.
- h. Install the LCD Module by using the mounting holes. When mounting the LCD module make sure it is free of twisting, warping and distortion. In particular, do not forcibly pull or bend the I/O cable or the backlight cable.
- i. Do not attempt to disassemble or process the LCD module.
- j. NC terminal should be open. Do not connect anything.
- k. If the logic circuit power is off, do not apply the input signals.
- l. Electro-Static Discharge Control. Since this module uses a CMOS LSI, the same careful attention should be paid to electrostatic discharge as for an ordinary CMOS IC. To prevent destruction of the elements by static electricity, be careful to maintain an optimum work environment.
  - Before removing LCM from its packing case or incorporating it into a set, be sure the module and your body have the same electric potential. Be sure to ground the body when handling the LCD modules.
  - Tools required for assembly, such as soldering irons, must be properly grounded. Make certain the AC power source for the soldering iron does not leak. When using an electric screwdriver to attach LCM, the screw driver should be of ground potentiality to minimize as much as possible any transmission of electromagnetic waves produced sparks coming from the commutator of the motor.

- To reduce the amount of static electricity generated, do not conduct assembly and other work under dry conditions. To reduce the generation of static electricity be careful that the air in the work environment is not too dry. A relative humidity of 50%-60% is recommended. As far as possible make the electric potential of your work clothes and that of the work bench the ground potential.
- The LCD module is coated with a film to protect the display surface. Exercise care when peeling off this protective film since static electricity may be generated.
- m. Since LCM has been assembled and adjusted with a high degree of precision, avoid applying excessive shocks to the module or making any alterations or modifications to it.
  - Do not alter, modify or change the shape of the tab on the metal frame.
  - Do not make extra holes on the printed circuit board, modify its shape or change the positions of components to be attached.
  - Do not damage or modify the pattern writing on the printed circuit board.
  - Absolutely do not modify the zebra rubber strip (conductive rubber) or heat seal connector.
  - Except for soldering the interface, do not make any alterations or modifications with a soldering iron.
  - Do not drop, bend or twist the LCM.

## 2. Storage Precautions

When storing the LCD modules, the following precaution are necessary.

- a. Store the LCD at a temperature from 10°C to 30°C and a relative humidity of 65% RH or less.
- b. Please store display in a dry place and shelter from direct sunlight.

## 3. Others

- a. Liquid crystals solidify under low temperature (below the storage temperature range) leading to defective orientation or the generation of air bubbles (black or white). Air bubbles may also be generated if the module is subject to a low temperature.
- b. If the LCD modules have been operating for a long time showing the same display patterns, the display patterns may remain on the screen as ghost images and a slight contrast irregularity may also appear. A normal operating status can be regained by suspending use for some time. It should be noted that this phenomenon does not adversely affect performance reliability.
- c. To minimize the performance degradation of the LCD modules resulting from destruction caused by static electricity etc. Exercise care to avoid holding the following sections when handling the modules.
  - Exposed area of the printed circuit board.
  - Terminal electrode sections.

## 4. Using LCD Modules

### a. Installing LCD Modules

The hole in the printed circuit board is used to fix LCM as shown in the picture below. Attend to the following items when installing the LCM.

- b. Cover the surface with a transparent protective plate to protect the polarizer and LC cell.

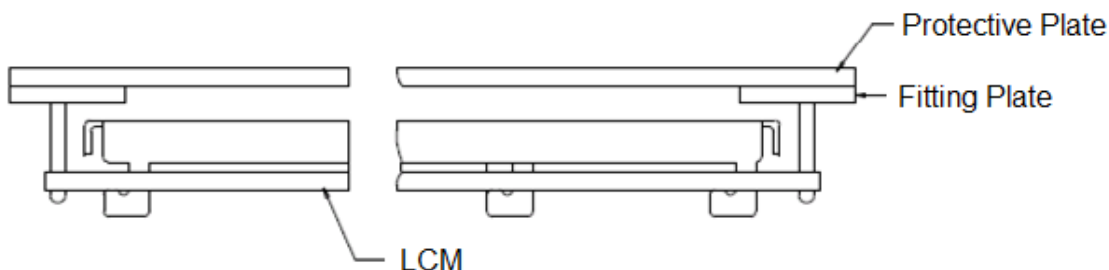

- c. When assembling the LCM into other equipment, the spacer to the bit between the LCM and the fitting plate should have enough height to avoid causing stress to the module surface, refer to the individual specifications for measurements. The measurement tolerance should be 0.1mm.
- d. Precaution for assemble the module with BTB connector:  
Please note the position of the male and female connector position, don't assemble or assemble like the method which the following picture shows.

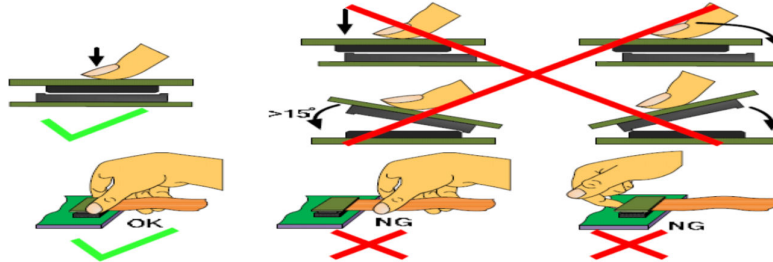

5. Precaution for soldering the LCM

|                 | Manual soldering             | Machine drag soldering            | Machine press soldering                           |
|-----------------|------------------------------|-----------------------------------|---|
| No RoHS Product | 290°C ~350°C.<br>Time: 3-5S. | 330°C ~350°C.<br>Speed: 4-8 mm/s. | 300°C ~330°C.<br>Time: 3-6S.<br>Press: 0.8~1.2Mpa |
| RoHS Product    | 340°C ~370°C.<br>Time: 3-5S. | 350°C ~370°C.<br>Time: 4-8 mm/s.  | 330°C ~360°C.<br>Time: 3-6S.<br>Press: 0.8~1.2Mpa |

- a. If soldering flux is used, be sure to remove any remaining flux after finishing the soldering operation (This does not apply in the case of a non-halogen type of flux). It is recommended that you protect the LCD surface with a cover during soldering to prevent any damage due to flux spatters.
- b. When soldering the electroluminescent panel and PC board, the panel and board should not be detached more than three times. This maximum number is determined by the temperature and time conditions mentioned above, though there may be some variance depending on the temperature of the soldering iron.
- c. When removing the electroluminescent panel from the PC board, be sure the solder has completely melted, the soldered pad on the PC board could be damaged.

6. Precautions for Operation

- a. Viewing angle varies with the change of liquid crystal driving voltage (VLCD). Adjust VLCD to show the best contrast.
- b. It is recommended to drive LCD's within the specified voltage limit since over limit will cause shorter LCD life. An electrochemical reaction due to direct current causes LCD deterioration. Avoid the use of direct current drive.
- c. Response time will be extremely delayed at lower temperature compared to room operating temperature range and on the other hand, at higher temperature LCD-shows dark colour in them. However those phenomena do not mean malfunction. The LCD will return to normal performance when ambient temperature revert to room condition.
- d. If the display area is pushed hard during operation, the display will become abnormal. However, it will return to normal if it is turned off and on.
- e. A slight dew depositing on terminals is a cause for electro-chemical reaction resulting in terminal open circuit.
- f. Input logic voltage before apply analogue high voltage such as LCD driving voltage when power on. Remove analogue high voltage before logic voltage when power off the module. Input each signal after the positive/negative voltage becomes stable.



- g. Please keep the temperature within the specified range for use and storage. Polarization degradation, bubble generation or polarizer peel-off may occur with high temperature and high humidity.

7. Safety

- a. It is recommended to crush damaged or unnecessary LCDs into pieces and wash them off with solvents such as acetone and ethanol, which should later be burned.
- b. If any liquid leaks out of a damaged glass cell and comes in contact with the hands, wash off thoroughly with soap and water.

8. Limited Warranty

Unless otherwise agreed between Crystal Clear Technology and customer, Crystal Clear Technology will replace or repair any of its LCD and LCM which is found to be defective electrically and visually when inspected in accordance with Crystal Clear Technology acceptance standards, for a period of one year from date of shipment. Confirmation of such date shall be based on freight documents. The warranty liability of Crystal Clear Technology is limited to repair and/or replacement on the terms set forth above. Crystal Clear Technology will not responsible for any subsequent or consequential events.

9. Return LCM under Warranty

No warranty can be granted if the precautions stated above have been disregarded. The typical examples of violations are:

- Broken LCD glass.
- PCB eyelet's damaged or modified.
- PCB conductors damaged.
- Circuit modified in any way, including addition of components.
- PCB tampered with by grinding, engraving or painting varnish.
- Soldering to, or modifying the bezel in any manner.

Module repairs will be invoiced to customer upon mutual agreement. Modules must be returned with sufficient description of failure or defects. Any connectors or cable installed by customer must be removed completely without damaging the PCB eyelet's, conductors and terminals.



### 10. Mechanical Specification

